

AP-425 RETROFIT

This Engineering Bulletin presents the latest improvements carried out to the **High Level Palletizer (AP-425) Overhead** turner re-design. This new design is now standard on our new **AP-400 series** and available as a retrofit. 100% retrofit with the majority of **AP-425**



Design

- Re-designed flaps for a smoother manipulation of the bags or bales
- Quicker and more precise movement through lighter design (50% less weight)
- The main shaft is no longer welded to the turner for easy manipulation
- Increased reliability through stronger construction & less need for adjustment
- Uses the same gearmotors as the previous design thus reducing the cost of the retrofit

Maintenance

- Less maintenance and adjustments required by removing the tension springs and adjustment chains
- Lubricated bushings eliminates greasing points on the main shaft
- Smoother movements due to less moving parts

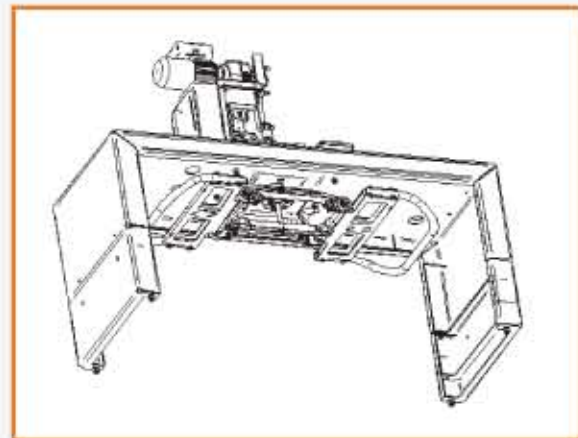
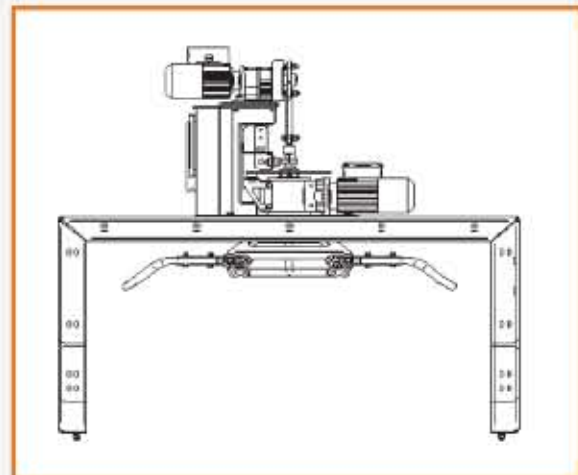

If you wish to improve your equipment, we will gladly answer your questions and provide you with a quotation.



**Premier Tech
Systems**

Francois Kirouac

☎ 418 867-8883 Ext. 6961

☎ 418 862-6642

@ service@premiertechsystems.com

WWW.PREMIERTECHSYSTEMS.COM